

#### Product Description

The function of a Liquid Level Switch is to detect and monitor liquid levels.

The level switch can be installed in a number of locations in the refrigeration system such as liquid receivers, suction line accumulators and compressor crankcases.

The range is designed for use with HCFC, HFC, HFO, CO<sub>2</sub>, A2L & HC refrigerants & associated oils where materially compatible. A 1" NPT level switch is recommended for ammonia applications.

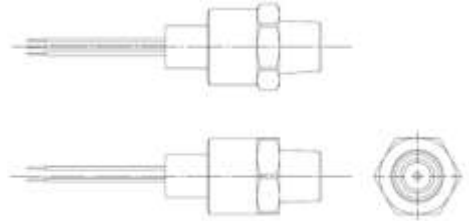

#### Product Features & Specifications

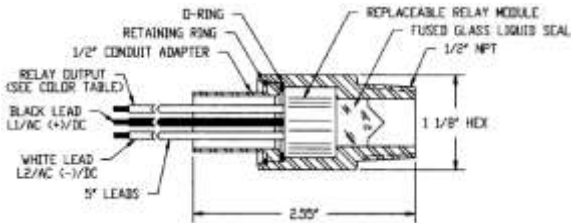

- Switches Solid State for liquid sensing
- No contact level sensing
- Servicable without loss of refrigerant
- Works with oil, refrigerants or any non-hazardous, non-corrosive fluids
- Glass prism in contact with fluid medium

- Maximum working pressure (S models): 46 barg
- Maximum working pressure (STH models): 130 barg
- Maximum working pressure (ST models): 140 barg
- Operating temperature range: -40°C to +99°C
- Mounting: Horizontal only
- Supply Voltage: Refer to table
- Resistive Rating: Refer to table
- Switch Inductive Rating: 36VA Pilot Duty Rated
- Contact life: Typically over 1 million cycles at rated electrical load
- Switch inductive ratings: 36 VA pilot duty rated
- Power for operation: 3.5mA AC, 5.5 mA DC
- Minimum load: 2mA (without bleed resistor)
- Contacts, Power Off: Open
- Contacts, Power On & Liquid Present: Refer to table
- Protection Class: IP 65 DIN models only

# Liquid Level Switches

## Application & Installation Instructions

Level Switch Number	Voltage	Resistive Rating	Contacts Liquid Present	Wire Colour Code	Replacement Module/Kit
9400	120V 50/60Hz	0.5 Amp	Closed	Yellow & White	2-044-012
9400-1	120V 50/60Hz	0.5 Amp	Closed	Yellow & White	2-044-012
9400A	120V 50/60Hz	0.5 Amp	Open	Yellow & White Stripe	2-044-017
9400A-1	120V 50/60Hz	0.5 Amp	Open	Yellow & White Stripe	2-044-017
9420	208/240V 50/60Hz	0.25 Amp	Closed	Red & White	A4416 (UK) 2-044-015 (USA)
9420-1	208/240V 50/60Hz	0.25 Amp	Closed	Red & White	2-044-015
9420A	208/240V 50/60Hz	0.25 Amp	Open	Red & White/Stripe	A4415 (UK) 2-044-018 (USA)
9420A-1	208/240V 50/60Hz	0.25 Amp	Open	Red & White/Stripe	2-044-018
9420DN	208/240V 50/60Hz	0.25 Amp	Closed	Red & White	A4425
9420DN-1	208/240V 50/60Hz	0.25 Amp	Closed	Red & White	A4863
9424	24V AC/DC	0.5 Amp	Closed	Orange & White	A4414 (UK) 2-044-013 (USA)
9424-1	24V AC/DC	0.5 Amp	Closed	Orange & White	2-044-013
9424-3/4UK	24V AC/DC	0.5 Amp	Closed	Orange & White	A4394
9424A	24V AC/DC	0.5 Amp	Open	Orange & White/Stripe	A4417 (UK) 2-044-020 (USA)
9424A-1	24V AC/DC	0.5 Amp	Open	Orange & White/Stripe	2-044-020
9424ADN	24V AC/DC	0.5 Amp	Open	Orange & White/Stripe	A4638
9424DN	24V AC/DC	0.5 Amp	Closed	Orange & White	A4424
9424DN-1	24V AC/DC	0.5 Amp	Closed	Orange & White	A4938
9424DN-3/4	24V AC/DC	0.5 Amp	Closed	Orange & White	A4424

### Nomenclature

Henry Liquid Level Switches are identified by four parts; 'S' Letter, Four-Digit Number, Letter Suffix, and Numerical Suffix. These are explained on the next page.

# Liquid Level Switches

## Application & Installation Instructions

All parts begin with an 'S' letter, signifying the operating pressure range as follows:

- 'S': 0 to 46 barg
- 'STH': 0 to 130 barg
- 'ST': 0 to 140 barg

The four digit number beginning '94' indicates the electrical ratings of the unit:

- 9400: 120V 50/60Hz AC, 0.5 Amp
- 9420: 208/240V 50/60Hz AC, 0.25 Amp
- 9424: 24V AC/DC, 0.5 Amp

The presence of a letter suffix after the four-digit number is used to indicate a reversed switch functionality, and a DIN plug or socket:

- A: Contacts will be Open when liquid is present
- DN: The switch is fitted with a DIN connector instead of flying leads

The connection size depends on whether or not the model has a numerical suffix:

- Models without a numerical suffix: 1/2" NPT
- Models with a '-3/4' suffix: 3/4" NPT
- Models with a '-1' suffix: 1" NPT

### Operation

The Henry level switch uses light reflecting from a conical glass prism as a means of detecting the absence of a liquid at the level of the glass cone. When no fluid covers the lower half of the cone, infra-red light from the module reflects from the mirror like inner surface of the cone back to a light detector signalling the electronic module to switch. When fluid covers the lower half of the glass cone, the light from the module passes into the fluid. This absence of light is detected by the module, which switches in the opposite direction.

### Installation

The Henry level switch is intended to be mounted horizontally. Since the level switch uses the passage of light into the fluid to detect high level, the user must prevent locating a reflective surface close to the inside end of the switch. The switch should be installed directly onto the equipment, avoiding branch extensions, to avoid the potential for a well effect which will in turn be detrimental to switch performance. A suitable pipe sealant should be used to seal the taper thread. The thread end should be tightened adequately to avoid leakage. For electrical safety, AC power supply level switches must be used on grounded equipment. The system should be de-pressurised before attempting any work. Failure to do so may result in bodily harm. Only suitably qualified personnel should only carry out installation, removal, etc. of this level switch.

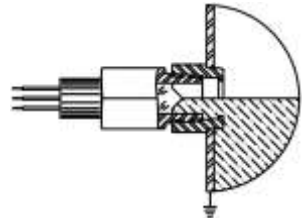

# Liquid Level Switches

## Application & Installation Instructions

### Optional 1" NPT Connection

A 1" NPT connection is available for the 9400 series by ordering with a "-1" suffix (i.e. 9424A-1). The 1" pipe thread connection allows the module to be mounted closer to the inner wall of the tank. This prevents the fitting from creating a pool of liquid next to the glass prism which, in certain applications, can be detrimental to the operation. The 1" connection is also recommended Ammonia applications where residue can build up on the sight glass.

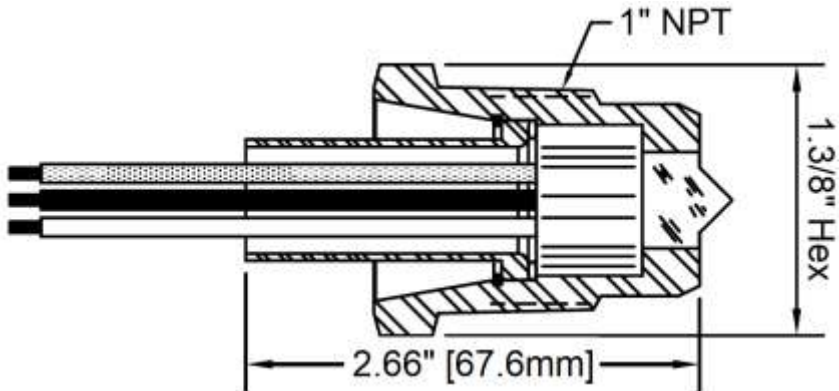

### Module Replacement

- i. Disconnect power at the fuse box
- ii. Remove wiring from the retainer
- iii. Remove the IRR 4000-93 Retaining Ring (1) with an IRR P-101 or equivalent retaining ring pliers
- iv. Remove the Retainer (2) and O-Ring (3)
- v. Pull out the Module (4) from the Switch Body (5) by the leads
- vi. Install new Module
- vii. Verify the voltage rating
- viii. Re-assemble the O-Ring, Retainer, Ring and wiring

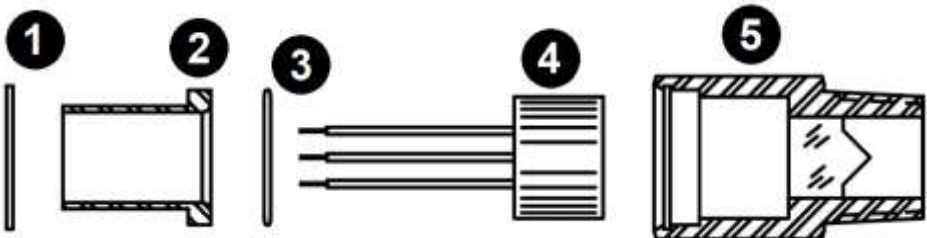

# Liquid Level Switches

## Application & Installation Instructions

### Application Wiring

Wiring diagrams for both AC and DC applications are shown below.

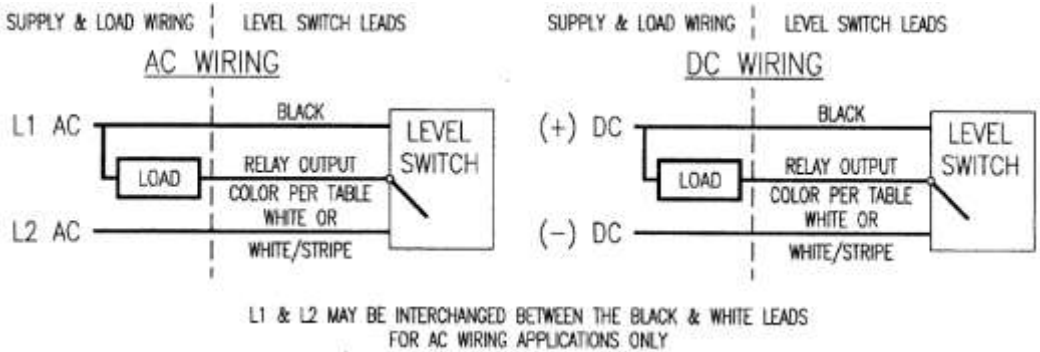

The 3 wire switching circuits shown below can be used in a number of applications. Some of the possible applications include:

- Solenoid valve operation for oil control in a refrigerant recovery/reclaim/recycle unit
- Indicate high or low level by means relay contact operation to a system controller
- Operate a relay to switch a high amperage load based on a level condition
- Switch a load through a time delay based on the level condition

### Anti-Short Cycle Timer, Delay On Make

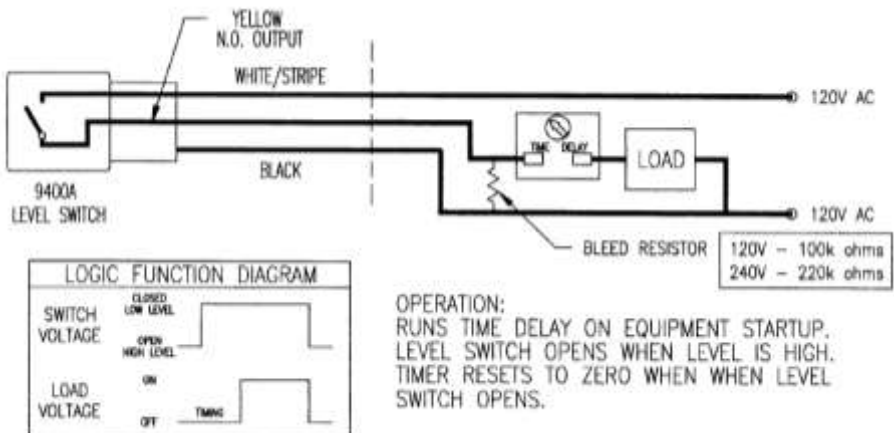

# Liquid Level Switches

## Application & Installation Instructions

### Anti-Short Cycle Timer, Delay On Break

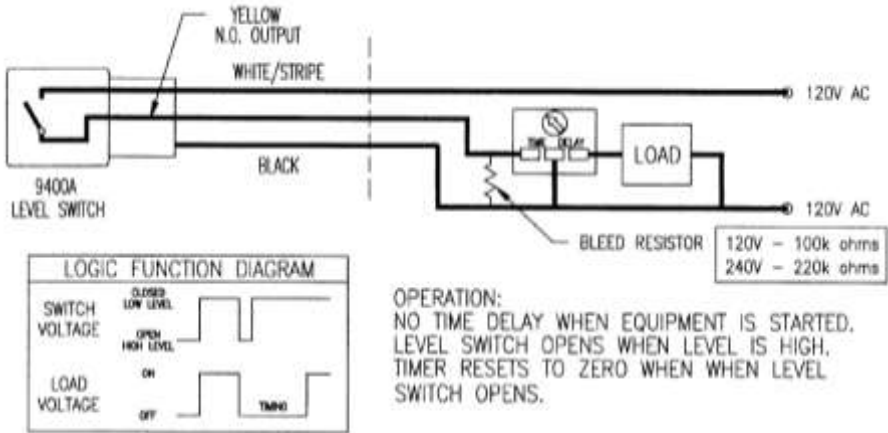

**NOTE:** THESE CIRCUITS ARE DRAWN AS A GENERAL GUIDE.  
THE USER MUST MAKE THE FINAL DESIGN OF WIRING AND TIME DELAY  
REQUIREMENTS WHICH FIT THE PARTICULAR APPLICATION.

### Differential Control Of Liquid Level Using 9400A Level Switch

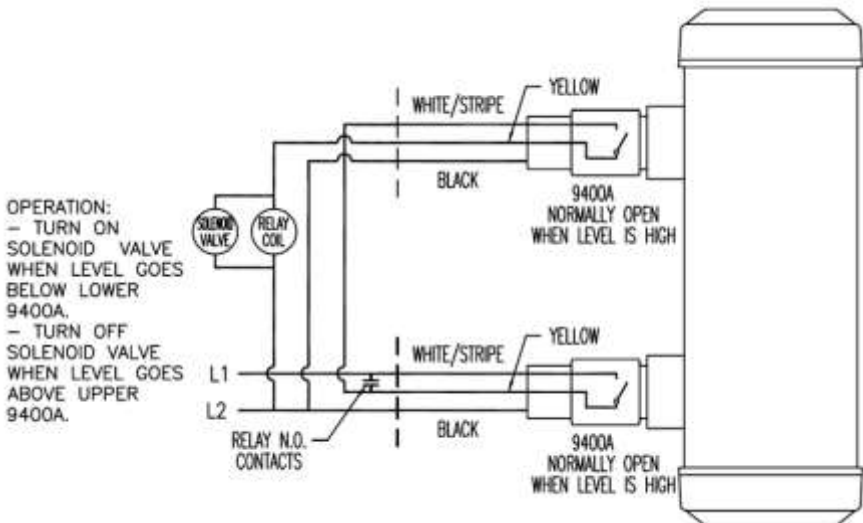

# Liquid Level Switches

## Application & Installation Instructions

### Application Wiring for DN Models

The wiring diagram is shown below. For DC supply, L1= +ve and L2 = -ve. For AC supply only, L1 and L2 may be interchanged.

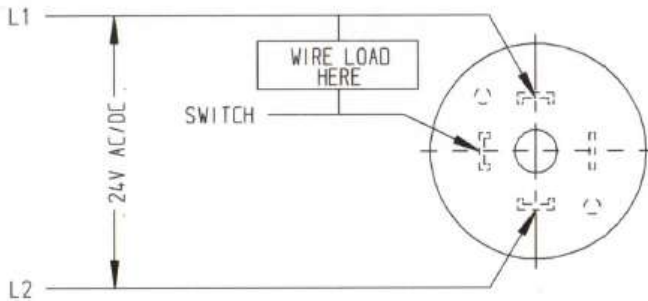
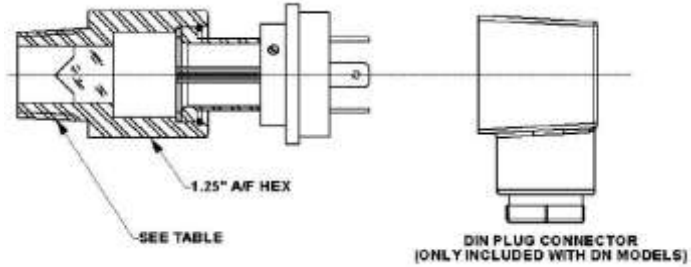

For 9420DN model, 208/240V is supplied across L1 and L2

Level Switch	L1	L2	Switch
9424-3/4UK & 9424DN	Black	White	Orange
9420DN	Black	White	Red
9424ADN	Black	White/Black	Orange
When wiring plug connector for DN models	Connection 1	Connection 2	Connection 3

# Liquid Level Switches

## Application & Installation Instructions

Troubleshooting 9400 Level Switches	
Complication	Possible Cause
Switch acts like there is no fluid at all times	<ul style="list-style-type: none"><li>A) The inner diameter of the tank or pipe should not be less than 1 1/8". When the diameter is less than 1 1/8", the light beam is reflected off of the back wall and back to the switch, even when liquid is present.</li><li>B) Additional sources of light, such as a sight glass directly across from the switch, will be picked up by the light detector in the module.</li></ul>
Switch acts like there is fluid present at all times	<ul style="list-style-type: none"><li>A) Fluid temperatures should remain in the ranges stated in the Level Switch Table. Colder, thicker fluids will take longer to drain away from the switch housing, delaying the switching action.</li><li>B) Low temperature applications (below 32°F) in humid environments can in some instances produce a frost layer on the glass between the housing and the module. The frost layer will absorb the light and the switch will act like there is fluid present.</li><li>C) The angle of the housing installation should be horizontal or sloping back into the tank (up to a 10° angle), to allow the fluid to drain away from the switch. To check for entrapped liquid, remove the module from the housing and view the glass. An empty glass should have two rings with approximately an 1/8" diameter dot in the centre of the smaller ring.</li></ul>
Switch "chatters" rapidly	<ul style="list-style-type: none"><li>A) Fluid splashing on the glass can give false readings as the glass is rapidly covered and drained of fluid</li></ul>
Module switches, but load does not switch	<ul style="list-style-type: none"><li>A) The size of the load that the switch is trying to pull should not exceed those stated in the level switch Specifications (Switch Resistive Ratings).</li></ul>

# Liquid Level Switches

Application & Installation Instructions

---

## Notes

---

### IF IN DOUBT, CONTACT HENRY TECHNOLOGIES

For local contact details,  
select the "Contact Us" option  
at;

[www.henry-group.net](http://www.henry-group.net)

### COMPONENT OF PRESUSRE EQUIPMENT CERTIFICATE

To view and download the COPE Certificate for your  
products, visit:  
[www.henry-group.net/technical/united-  
kingdom](http://www.henry-group.net/technical/united-kingdom)  
or scan the QR Code opposite:



Select **Product Manufactured in the UK > COPE Products > COPE\_LL**P to open  
and download your COPE Certificate.